

UNITED STATES PATENT AND TRADEMARK OFFICE

BEFORE THE PATENT TRIAL AND APPEAL BOARD

JUNIPER NETWORKS, INC. and PALO ALTO NETWORKS, INC.,
Petitioner,

v.

PACKET INTELLIGENCE LLC,
Patent Owner.

IPR2020-00338
Patent 6,839,751 B1

Before CHARLES J. BOUDREAU, JOHN D. HAMANN, and
KRISTI L. R. SAWERT, *Administrative Patent Judges*.

BOUDREAU, *Administrative Patent Judge*.

DECISION
Granting Institution of *Inter Partes* Review
35 U.S.C. § 314, 37 C.F.R. § 42.4

I. INTRODUCTION

Juniper Networks, Inc. and Palo Alto Networks, Inc. (collectively “Petitioner”) filed a Petition (Paper 3, “Pet.”) requesting an *inter partes* review of claims 1, 2, 5, 10, 14, 15, and 17 of U.S. Patent No. 6,839,751 B1 (Ex. 1004, “the ’751 patent”) pursuant to 35 U.S.C. § 311. Packet Intelligence LLC (“Patent Owner”) filed a Patent Owner Preliminary Response (Paper 7, “Prelim. Resp.”). Petitioner filed a Preliminary Reply (Paper 10, “Prelim. Reply”) and Patent Owner filed a Preliminary Sur-Reply (Paper 11, “Prelim. Sur-Reply”) in accordance with our Order (Paper 9) allowing the parties to address the applicability of the Board’s decision in *Apple Inc. v. Fintiv, Inc.*, IPR2020-00019, Paper 11 (PTAB Mar. 20, 2020) (precedential) (“*Fintiv*”).

We have authority to determine whether to institute an *inter partes* review under 35 U.S.C. § 314 and 37 C.F.R. § 42.4(a). An *inter partes* review may be instituted if “the information presented in the petition filed under section 311 and any response filed under section 313 shows that there is a reasonable likelihood that the petitioner would prevail with respect to at least 1 of the claims challenged in the petition.” 35 U.S.C. § 314(a).

Upon consideration of the preliminary papers, for the reasons that follow and on this record, we are persuaded that Petitioner demonstrates a reasonable likelihood of prevailing in showing the unpatentability of at least one of the challenged claims. Accordingly, we institute an *inter partes* review.

A. Related Matters

The parties identify two district court litigations as related matters that involve the ’751 patent: *Packet Intelligence LLC v. Juniper Networks, Inc.*, 3:19-cv-04741 (N.D. Cal.) and *Palo Alto Networks, Inc. v. Packet*

Intelligence LLC, No. 3:19-cv-02471 (N.D. Cal). Pet. 1; Paper 5, 2. The parties also identify as related matters *Packet Intelligence LLC v. NetScout Systems, Inc.*, 2:16-cv-230-JRG (E.D. Tex.) and *Packet Intelligence LLC v. NetScout Sys., Inc.*, 19-2041 (Fed. Cir.).¹ Pet. 1; Paper 5, 2.

In addition, the parties identify the following matters pending before the Board, challenging claims of patents related to the '751 patent: IPR2020-00335, IPR2020-00336, IPR2020-00337, IPR2020-00339, IPR2020-00485, and IPR2020-00486.² Pet. 1; Paper 5, 2–3. Lastly, the parties collectively identify the following matters, no longer pending before the Board, as being related: (i) IPR2017-00451 and IPR2019-01289, which challenged certain claims of the '751 patent; and (ii) IPR2017-00450, IPR2017-00629, IPR2017-00630, IPR2017-00769, IPR2017-00862, IPR2017-00863, IPR2019-01290, IPR2019-01291, IPR2019-01292, and IPR2019-01293, which challenged claims of patents related to the '751 patent. Pet. 2; Paper 5, 3–5.

B. The '751 Patent

The '751 patent, titled “Re-using Information from Data Transactions for Maintaining Statistics in Network Monitoring,” discloses a “method of and monitor apparatus for analyzing a flow of packets passing through a connection point on a computer network.” Ex. 1004, codes (54), (57). The

¹ A copy of the Final Judgment in Case No. 2:16-cv-00230, dated September 7, 2018, has been filed by Patent Owner in the record of this proceeding as Exhibit 2059, and a copy of the Decision of the U.S. Court of Appeals for the Federal Circuit in Appeal No. 19-2041, dated July 14, 2020, has been filed by Patent Owner in the record of this proceeding as Exhibit 2060.

² Decisions denying institution of *inter partes* review in IPR2020-00335 and IPR2020-00485 were entered on August 27, 2020.

'751 patent explains that there was a need in the art for “a real-time network monitor that can provide details as to the application programs being used.” *Id.* at 1:54–59. The disclosed monitor receives packets passing in either direction through its connection point on the network and “elucidate[s] what application programs are associated with each packet” by extracting information from the packet, using selected parts of the extracted information to “build[] a signature for identifying the conversational flow of the packet,” and performing a lookup of “a database of flow records for previously encountered conversational flows to determine whether [the] signature is from an existing flow.” *Id.* at 2:11–42, 6:5–19, Fig. 1.

Figure 3 of the '751 patent is reproduced below.

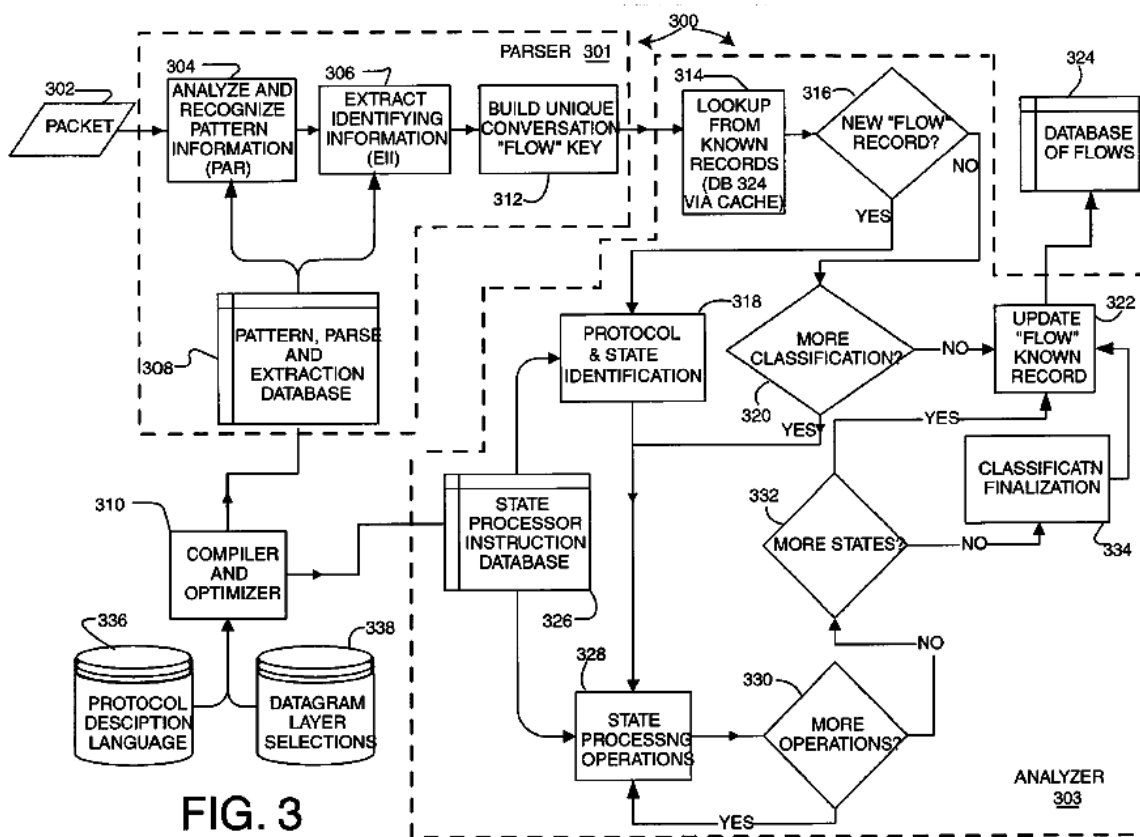

Figure 3, above, depicts various components of network packet monitor 300, including parser subsystem 301, analyzer subsystem 303, and database of

known flows 324. Ex. 1004, 8:47–9:2. Parser subsystem 301 “parses the packet and determines the protocol types and associated headers for each protocol layer that exists in the packet 302,” “extracts characteristic portions (signature information) from the packet 302,” and builds the “unique flow signature (also called a ‘key’) for this flow.” *Id.* at 9:16–10:39, 29:9–31:6 (describing an example of how the disclosed monitor builds signatures and flow states in the context of a Sun Remote Procedure Call (RPC), where, after all of the required processing, “KEY-2 may . . . be used to recognize packets that are in any way associated with the application ‘a²’”), Fig. 2.

Analyzer system 303 then determines whether the packet has a matching flow-entry in database of flows 324, and processes the packet accordingly, including, for example, determining whether the packet belongs to an existing conversational flow or a new (i.e., not previously encountered) flow and, in the case of the latter, performing state processing to determine whether the conversational flow has been “fully characterized” and should be finalized. Ex. 1004, 10:56–13:44. The ’751 patent discloses that

[f]uture packets that are part of the same conversational flow have their state analysis continued from a previously achieved state. When enough packets related to an application of interest have been processed, a final recognition state is ultimately reached, i.e., a set of states has been traversed by state analysis to completely characterize the conversational flow. The signature for that final state enables each new incoming packet of the same conversational flow to be individually recognized in real time.

In this manner, one of the great advantages of the present invention is realized. Once a particular set of state transitions has been traversed for the first time and ends in a final state, a short-cut recognition pattern—a signature—an [sic] be generated that will key on every new incoming packet that relates to the conversational flow. Checking a signature involves a simple

operation, allowing high packet rates to be successfully monitored on the network.

Id. at 13:11–27.

C. Illustrative Claim

Among the challenged claims, claims 1 and 17 are independent.

Claim 1, reproduced below, is illustrative.

1. A method of analyzing a flow of packets passing through a connection point on a computer network, the method comprising:

(a) receiving a packet from a packet acquisition device coupled to the connection point;

(b) for each received packet, looking up a flow-entry database for containing one or more flow-entries for previously encountered conversational flows, the looking up to determine if the received packet is of an existing flow, a conversational flow including an exchange of a sequence of one or more packets in any direction between two network entities as a result of a particular activity using a particular layered set of one or more network protocols, a conversational flow further having a set of one or more states, including an initial state;

(c) if the packet is of an existing flow, identifying the last encountered state of the flow, performing any state operations specified for the state of the flow, and updating the flow-entry of the existing flow including storing one or more statistical measures kept in the flow-entry; and

[(d) if the packet is of a new flow, performing any state operations required for the initial state of the new flow and storing a new flow-entry for the new flow in the flow-entry database, including storing one or more statistical measures kept in the flow-entry,

wherein every packet passing though the connection point is received by the packet acquisition device, and

wherein at least one step of the set consisting of of [sic] step (a) and step (b) includes identifying the protocol being used in the

packet from a plurality of protocols at a plurality of protocol layer levels,

such that the flow-entry database is to store flow entries for a plurality of conversational flows using a plurality of protocols, at a plurality of layer levels, including levels above the network layer.

Ex. 1004, 50:23–60.

D. Asserted Grounds of Unpatentability

Petitioner asserts the following grounds of unpatentability:

Claim(s) Challenged	35 U.S.C. §³	Reference(s)/Basis
1, 2, 5, 10, 14, 15, 17	103(a)	Riddle, ⁴ Ferdinand ⁵
1, 2, 5, 10, 14, 15, 17	103(a)	Riddle, Ferdinand, Yu ⁶
1, 2, 5, 10, 14, 15, 17	103(a)	Riddle, Ferdinand, RFC1945 ⁷

Pet. 7, 17–91. Petitioner submits the Declaration of Dr. Jon B. Weissman (Ex. 1006) in support of its arguments.

³ The Leahy-Smith America Invents Act (“AIA”) included revisions to 35 U.S.C. § 103 that became effective on March 16, 2013. Because the ’751 patent issued from an application filed before March 16, 2013, we apply the pre-AIA version of the statutory basis for unpatentability.

⁴ Riddle et al., US 6,412,000 B1 (issued June 25, 2002) (Ex. 1008).

⁵ Ferdinand et al., WO 92/19054 (published Oct. 29, 1992) (Ex. 1009).

⁶ Yu, US 6,625,150 B1 (issued Sept. 23, 2003) (Ex. 1011).

⁷ T. Berners-Lee et al., *Hypertext Transfer Protocol -- HTTP/1.0*, Request for Comments: 1945, Network Working Group (May 1996) (Ex. 1010).

II. DISCUSSION

A. Discretionary Denial Under 35 U.S.C. § 314(a)

Institution of an *inter partes* review is discretionary. Section 314(a) of title 35 of the United States Code provides that “[t]he Director may not authorize an inter partes review to be instituted unless the Director determines that the information presented in the petition . . . and any response . . . shows that there is a reasonable likelihood that the petitioner would prevail with respect to at least 1 of the claims challenged in the petition.” The Supreme Court has explained that, because § 314 includes no mandate to institute review, “the agency’s decision to deny a petition is a matter committed to the Patent Office’s discretion.” *Cuozzo Speed Techs., LLC v. Lee*, 136 S. Ct. 2131, 2140 (2016); *see also Harmonic Inc. v. Avid Tech., Inc.*, 815 F.3d 1356, 1367 (Fed. Cir. 2016) (explaining that under § 314(a), “the PTO is permitted, but never compelled, to institute an IPR proceeding”). The Director has delegated his authority under § 314(a) to the Board. 37 C.F.R. § 42.4(a) (“The Board institutes the trial on behalf of the Director.”).

As the November 2019 Consolidated Trial Practice Guide⁸ (“CTPG”) noted, the Leahy-Smith America Invents Act (“AIA”) was “designed to establish a more efficient and streamlined patent system that will improve patent quality and limit unnecessary and counterproductive litigation costs.” CTPG at 56 (quoting H.R. Rep. No. 112-98, pt. 1, at 40 (2011), 2011 U.S.C.C.A.N. 67, 69 (stating that post grant reviews were meant to be “quick and cost effective alternatives to litigation”)) (citing S. Rep. No.

⁸ Available at <https://www.uspto.gov/sites/default/files/documents/tpgnov.pdf>.

110-259, at 20 (2008)). The Board has recognized these goals of the AIA, but also has “recognize[d] the potential for abuse of the review process by repeated attacks on patents.” *Gen. Plastic Co. v. Canon Kabushiki Kaisha*, IPR2016-01357, Paper 19 at 16–17 (PTAB Sept. 6, 2017) (precedential as to § II.B.4.i) (“*General Plastic*”).

Patent Owner argues that we should exercise our discretion under 35 U.S.C. § 314(a) to deny the Petition for two reasons: first, because there are two co-pending district-court litigations that “have advanced into the claim construction process and are into discovery regarding infringement and validity issues”; and second, because “the instant petition is a serial petition attacking the same patents and claims that have been challenged in prior petitions.” Prelim. Resp. 27–38; Prelim. Sur-Reply 1. Petitioner disagrees. Pet. 4–5; Prelim. Reply 1–10.

1. Parallel District Court Proceedings

As noted above, there are two co-pending district-court litigations involving the ’751 patent and the same parties: *Packet Intelligence LLC v. Juniper Networks, Inc.*, 3:19-cv-04741 (N.D. Cal.) and *Palo Alto Networks, Inc. v. Packet Intelligence LLC*, No. 3:19-cv-02471 (N.D. Cal) (collectively, “the co-pending litigations”). *See supra* § I.A. Pointing to these co-pending litigations, Patent Owner argues that institution in this proceeding would not be an effective alternative to those litigations, nor an efficient use of the Board’s limited resources. Prelim. Resp. 1, 27–34.

In determining whether to exercise discretion to deny institution under § 314(a) on behalf of the Director for reason of parallel court proceeding(s), we are guided by the Board’s precedential decisions in *NHK Spring Co. v. Intri-Plex Techs., Inc.*, IPR2018-00752, Paper 8 (PTAB Sept. 12, 2018) (“*NHK*”) and *Fintiv*. In *NHK*, the Board found that the “advanced state of

the district court proceeding” was a “factor that weighs in favor of denying” the petition under § 314(a). *NHK*, Paper 8 at 20. The Board determined that “[i]nstitution of an *inter partes* review under these circumstances would not be consistent with ‘an objective of the AIA . . . to provide an effective and efficient alternative to district court litigation.’” *Id.* (citing *Gen. Plastic* at 16–17).

In *Fintiv*, the Board explained that “cases addressing earlier trial dates as a basis for denial under *NHK* have sought to balance considerations such as system efficiency, fairness, and patent quality.” *Fintiv*, Paper 11 at 5. *Fintiv* sets forth six non-exclusive factors for determining “whether efficiency, fairness, and the merits support the exercise of authority to deny institution in view of an earlier trial date in the parallel proceeding.” *Id.* at 6. These factors consider:

1. whether the court granted a stay or evidence exists that one may be granted if a proceeding is instituted;
2. proximity of the court’s trial date to the Board’s projected statutory deadline for a final written decision;
3. investment in the parallel proceeding by the court and the parties;
4. overlap between issues raised in the petition and in the parallel proceeding;
5. whether the petitioner and the defendant in the parallel proceeding are the same party; and
6. other circumstances that impact the Board’s exercise of discretion, including the merits.

Id. at 5–6. We discuss the parties’ arguments in the context of considering the above factors. In evaluating the factors, we take a holistic view of whether efficiency and integrity of the system are best served by denying or instituting review. *Id.* at 6.

a. Whether the court granted a stay or evidence exists that one may be granted if a proceeding is instituted

Patent Owner argues that “this factor strongly favors discretionary denial” because Petitioner has not moved for a stay of the co-pending litigations and because the District Court would be unlikely to grant a stay in any event. Prelim. Resp. 29–30. As to the latter, Patent Owner directs us to an exchange that occurred during a joint case-management conference between counsel for Petitioner and the District Court. *Id.* (citing Ex. 2005, 10–11). Patent Owner argues that the District Court’s statement to the Petitioner to “[s]ave your money” shows that the district court would be unlikely to grant a stay should Petitioner move for one. *Id.* (emphasis omitted). Petitioner contends that Patent Owner mischaracterizes the exchange, and that the District Court simply advised Petitioner that it would not grant a motion to stay pre-institution. Prelim. Reply 4–5. On consideration of the parties’ respective arguments and evidence, we find that Petitioner has the better position.

As Petitioner points out, the exchange between counsel for Petitioner and the District Court related to Petitioner’s inquiry as to whether the District Court would be amenable to granting a motion to stay *pre-institution*. Prelim. Reply 4. Specifically, Petitioner asked about “fil[ing] a stay motion based on the filing of the IPRs not waiting until the petitions are ruled on.” Ex. 2005, 10–11. The District Court indicated that, in the past, it “granted them sort of willy-nilly,” but no longer does so. *Id.* We agree with Petitioner that this exchange relates to the District Court’s inclination to grant a stay based solely on filing a petition, not based on a decision whether or not to institute this proceeding. Prelim. Reply 4. Accordingly, we find that the cited exchange has little probative value with respect to the question

of whether “evidence exists that [a stay] may be granted if a proceeding is instituted” under the first *Fintiv* factor.

Petitioner contends that the District Court would likely stay the co-pending litigations if this proceeding is instituted. Prelim. Reply 4–5. Petitioner contends that the district court “already stated in the prior [case-management conference] that institution of relevant IPRs^{9]} would result in a stay.” *Id.* at 4 (citing Ex. 1084, 7–8 (case management conference of August 20, 2019)). Petitioner also contends that the District Court’s inclination to grant stays is confirmed by two recent decisions granting motions to stay in *J&K IP Assets, LLC v. Armaspec, Inc.* (Case No. 17-cv-07308-WHO (N.D. Cal. Apr. 24, 2019)) and *Contour IP Holding, LLC v. GoPro* (2018 WL 6574188, *2–*3 (N.D. Cal. Dec. 12, 2018)). *Id.* at 5 (citing Ex. 1098; Ex. 1099). Patent Owner argues that those decisions are inapt because the District Court’s “recent activity concerning stays pending IPRs indicates that [it] will grant such a stay when agreed to by the parties.” Prelim. Sur-Reply 3 (citing Ex. 2050). Patent Owner also argues that the District Court’s statements during the case-management conference are not relevant because “that conference related to different IPRs that were filed less than two months after [Petitioner] filed its complaint in the co-pending district court litigation.” *Id.* at 2 (citing Ex. 2044; Ex. 2045; Ex. 2046; Ex. 2047; Ex. 2048; Ex. 2049). Here, however, the Petition was filed approximately nine months after the complaint was filed. *Id.*

⁹ During this case management conference, the district court was inquiring as to the status of IPR petitions filed by Nokia in July 2019 against some of the same patents being asserted in the parallel proceeding against petitioners here.

We find that the record contains adequate evidence that the District Court may grant a stay upon institution. Specifically, after observing that “there are so many PTAB proceedings,” the District Court stated that “if they are instituted . . . [t]his will cause a stay in the proceedings.” Ex. 1084, 7:22–24, 8:12–14. We acknowledge that the District Court’s statements are not specifically directed to this proceeding, because the case-management conference took place before the Petition was filed. *See id.* at 3:1 (setting forth a date of August 20, 2019). Even so, the District Court’s statements provide some evidence that it *may* grant a stay upon institution considering all circumstances at the time the motion is filed. *Id.* at 8:15–18.

For these reasons, we find that the first *Fintiv* factor does not support exercising our discretion to deny institution pursuant to § 314(a).

b. Proximity of the court’s trial date to the Board’s projected statutory deadline for a final written decision

A trial in *Palo Alto Networks, Inc. v. Packet Intelligence LLC* is currently scheduled to start on August 30, 2021. Ex. 2006, 3. A trial in *Packet Intelligence LLC v. Juniper Networks, Inc.* is currently scheduled to start on September 13, 2021. Ex. 2007, 2. The Board’s projected statutory deadline for a final written decision is September 9, 2021. *See* 35 U.S.C. § 316(a)(11). Patent Owner argues that the second *Fintiv* factor “slightly favors discretionary denial” because “the first trial date is before the statutory deadline for a final written decision,” and “the second only two days after the statutory deadline.” Prelim. Resp. 31. In contrast, Petitioner contends that this factor “weighs slightly against denial,” because both trial dates are tentative due to the COVID-19 pandemic and because Patent Owner has previously expressed a “preference for a three-month gap” between the first trial in *Palo Alto Networks, Inc. v. Packet Intelligence LLC*

and the second trial in *Packet Intelligence LLC v. Juniper Networks, Inc.* Prelim. Reply 5–6 (citing Ex. 2005, 4, 8). Patent Owner responds that it “currently does not intend to request an additional extension of the Juniper schedule.” Prelim. Sur-Reply 4. Patent Owner also argues that “[t]o the extent the district court litigations incur additional delays due to COVID-19, it is likely that PTAB proceedings will incur similar delays.” *Id.* at 4–5.

We determine that, on this record, the second *Fintiv* factor weighs against exercising our discretion to deny institution pursuant to § 314(a). Patent Owner’s statement that it does not *currently intend* to seek an additional extension of time for the second trial is equivocal. And, although the first trial is currently scheduled to begin days before a final written decision is due, we find that it is more likely that the District Court will incur delays due to the COVID-19 pandemic than the Board. The Board has explained that, “barring exceptional circumstances, the Board adheres to a one-year statutory deadline prescribed by 35 U.S.C. § 316(a)(11) for entry of final decisions in instituted *inter partes* reviews.” *Sand Revolution II, LLC v. Cont’l Intermodal Grp.-Trucking LLC*, IPR2019-01393, Paper 24 at 8–10 (PTAB June 16, 2020). And “even in the extraordinary circumstances under which the entire country is currently operating because of the COVID-19 pandemic, the Board continues to be fully operational” and meeting all statutory deadlines for final written decisions. *Id.* We note that during the same period, the District Court agreed to reschedule the first trial date, and, unlike the Board, the District Court is not bound by a statutory deadline when considering further extensions or changed circumstances. Ex. 1093.

c. Investment in the parallel proceeding by the court and the parties

Patent Owner argues that the third *Fintiv* factor weighs in favor of discretionary denial because the parties have made “significant investments in discovery, contentions, and claim construction to date.” Prelim. Resp. 33. Specifically, Patent Owner argues that the parties “have been engaged in extensive discovery and code review,” “exchanged infringement and invalidity contentions,” “exchanged claim construction positions and evidence,” and filed “[o]pening claim construction briefs.” *Id.* at 31–32. Petitioner contends that this factor does not weight in favor of discretionary denial because discovery “is far from complete.” Prelim. Reply 7. For example, Petitioner contends, “[n]o fact witnesses or experts have been deposed” and “[t]here has been no expert discovery.” *Id.*

We have reviewed the parties’ respective arguments and evidence and determine that the third *Fintiv* factor weighs against exercising our discretion to deny institution pursuant to § 314(a). Although it is clear that the parties have invested significant effort in the discovery process, discovery is not yet complete. Prelim. Reply 7. We are also not aware of any decision by the District Court on claim construction. In light of these facts, the investment of time and effort that remains to bring the co-pending litigations to trial appears to far outweigh that which has already been invested.

d. Overlap between issues raised in the petition and in the parallel proceeding

Patent Owner argues that the fourth *Fintiv* factor “weighs strongly in favor of discretionary denial” because the co-pending litigations “will address substantially the same invalidity theories.” Prelim. Resp. 33. Patent

Owner points out that Petitioner relies on the same prior-art references (i.e., Riddle, Ferdinand, Yu, and RFC1945) in both this Petition and the co-pending litigations. *Id.* Petitioner contends that it is “premature to compare arguments, evidence, or issues” because Patent Owner has yet to respond to Petitioner’s invalidity contentions in the co-pending litigations. Prelim. Reply 8. Petitioner also contends that it challenges claims in this Petition that it has yet to challenge in the co-pending litigations, and thus, “these IPRs will address the validity of claims, and likely whole patents, that the district court trials will not address.” *Id.* Finally, Petitioner argues that this factor weighs against discretionary denial because Patent Owner has asserted its patents against network router sellers and manufacturers “and a public trial record of the important invalidity grounds in the Petition will reduce issues for the public.” *Id.*

Upon consideration of the parties’ respective arguments, as well as the possibilities that the district court may stay the related litigations or at least postpone the trial dates (*see supra* §§ II.A.1.a, II.A.1.b), we find that the fourth *Fintiv* factor weighs against exercising our discretion to deny institution pursuant to § 314(a). Specifically, we find there is a reasonable likelihood that the Board will address the overlapping validity issues prior to the district court reaching them at trial in either of the related litigations, thereby providing the possibility of simplifying issues for trial in those litigations. *See, e.g., MED-EL Elektromedizinische Geraete GmbH v. Sonova AG*, IPR2020-00176, Paper 13 at 15 (PTAB June 3, 2020) (“*MED-EL*”) (“As to the fourth factor, the parties do not dispute that overlap exists between the invalidity issues in this case and in the district court. This overlap may inure to the district court’s benefit, however, by simplifying

issues for trial should we reach our determination on the challenges raised in the Petition before trial.”).

e. Whether the petitioner and the defendant in the parallel proceeding are the same party

There is no dispute that the Petitioner is the defendant in the co-pending litigations. There is no dispute that the Petitioner is the defendant in the co-pending litigations. Nonetheless, given the considerations discussed above with respect to factors one, two, and four, and the concomitant possibility that the Board will reach a decision on validity before the district court does so, thereby giving rise to potential estoppel against Petitioner, we regard this factor as neutral or weighing at most slightly in favor of denial. *See, e.g., MED-EL* at 15 (concluding that factor 5 weighed slightly in favor of denial where the petitioner was also the defendant in the district court proceeding).

f. Other circumstances that impact the Board’s exercise of discretion, including the merits

Patent Owner argues that the sixth *Fintiv* factor weighs in favor of discretionary denial because “none of Riddle, Yu, or RFC 1945 disclose the claimed ‘conversational flows.’” Prelim. Resp. 34. For the reasons explained below, however, we preliminarily determine that the prior art teaches or suggests “conversational flows” as claimed. *See infra* §§ II.E, II.F. Thus, this factor does not support exercising our discretion to deny institution pursuant to § 314(a). *See also* Prelim. Reply 9.

g. Weighing the Factors

We agree with Petitioner that the factors on balance do not favor discretionary denial. Although no single factor is dispositive, the fact that the Board will issue its final written decision within one year of the date for

institution under 35 U.S.C. § 316(a)(11)—whereas the trial dates for the co-pending litigations are currently set to occur around the same time as the due date for the final written decision, and being so far distant from the date of this Decision, they are uncertain given the COVID-19 pandemic (factor two), and the fact that the District Court has indicated that institution of relevant IPRs may result in a stay (factor one) weigh heavily against discretionary denial. Of the remaining factors, we find only the fifth factor potentially to weigh slightly in favor of discretionary denial, and even then not sufficiently to tip the balance in our holistic review of all of the *Fintiv* factors. For these reasons, we decline to exercise our discretion to deny institution under § 314(a).

2. *Serial Petitions*

Patent Owner also argues that we should exercise discretion under 35 U.S.C. § 314(a) to deny the Petition because “the instant petition is a serial petition attacking the same patents and claims that have been challenged in prior petitions.” Prelim. Resp. 28. In particular, Patent Owner argues that the Petition should be denied “because the Board has already considered prior petitions to the same patents and claims.” *Id.* Petitioner contends that the Board should not deny institution, because this Petition is the first and only petition filed by Petitioner with respect to the ’751 patent and because the Board has never issued a final written decision or addressed any of the grounds in this Petition. Pet. 4–5.

In *General Plastic*, the Board articulated a non-exhaustive list of factors to consider in evaluating whether to exercise discretion under § 314(a) to deny a petition that challenges a patent that was previously challenged before the Board. These factors are:

1. whether the same petitioner previously filed a petition directed to the same claims of the same patent;
2. whether at the time of filing of the first petition the petitioner knew of the prior art asserted in the second petition or should have known of it;
3. whether at the time of filing of the second petition the petitioner already received the patent owner's preliminary response to the first petition or received the Board's decision on whether to institute review in the first petition;
4. the length of time that elapsed between the time the petitioner learned of the prior art asserted in the second petition and the filing of the second petition;
5. whether the petitioner provides adequate explanation for the time elapsed between the filings of multiple petitions directed to the same claims of the same patent;
6. the finite resources of the Board; and
7. the requirement under 35 U.S.C. § 316(a)(11) to issue a final determination not later than 1 year after the date on which the Director notices institution of review.

Gen. Plastic at 9–10. These factors are “a non-exhaustive list” and “additional factors may arise in other cases for consideration, where appropriate.” *Id.* at 16, 18; *see also* CTPG at 58 (stating that “[t]he *General Plastic* factors are also not exclusive” and that “[t]here may be other reasons” that “favor[] denying a petition”).

a. Whether the same petitioner previously filed a petition directed to the same claims of the same patent

As Patent Owner points out, all claims of the '751 patent were challenged previously in IPR2017-00451, filed by Sandvine Corp. and Sandvine Inc. ULC (“Sandvine”). Prelim. Resp. 35. The Board denied institution in that proceeding on July 26, 2017. IPR2017-00451 (Paper 8). Certain claims of the '751 patent were also challenged previously in

IPR2019-01289 by Nokia Corp. and Nokia of America Corp. (collectively, “Nokia”). Before Patent Owner filed a preliminary response in that proceeding, the Board granted the parties’ joint motion to terminate. IPR2019-01289 (Paper 9).

Patent Owner acknowledges that the petitioners are not the same, but argues that “the claims challenged in the instant petition were already challenged in the prior petitions” and “the arguments Petitioner[] present[s] are substantially the same arguments the Board has already rejected numerous times.” Prelim. Resp. 35.

We have considered Patent Owner’s arguments but determine that the first *General Plastic* factor weighs against exercising our discretion to deny institution. Under this factor, we consider “whether the same petitioner previously filed a petition directed to the same claims of the same patent.” *Gen. Plastic* at 16. Petitioner, as Patent Owner admits, has not previously filed any petition directed to the ’751 patent. In addition, there is no evidence of record that Petitioner shares any relationship with Sandvine or Nokia. *See Valve Corp. v. Elec. Scripting Prods., Inc.*, IPR2019-00062, -00063, -00084, Paper 11 at 9 (PTAB April 2, 2019) (precedential) (stating that “when different petitioners challenge the same patent, we consider any relationship between those petitioners when weighing the *General Plastic* factors”).

b. Whether, at the time of filing of the first petition, the petitioner knew of the prior art asserted in the second petition or should have known of it

Patent Owner argues that the second *General Plastic* factor weighs in favor of denial because Petitioner knew of, or should have known of,

prior-art references Riddle, Yu, and RFC1945 for many years before filing this Petition. Prelim. Resp. 36.

The second *General Plastic* factor relates to “whether a petitioner should have or could have raised the new challenges earlier.” *Gen. Plastic* at 18. Here, however, Patent Owner’s arguments do not show any relationship between Petitioner and Sandvine or Nokia at the times Sandvine and Nokia filed their respective petitions. Thus, whether Petitioner knew of, or should have known of, the prior art relied upon in this Petition at the time Sandvine and/or Nokia filed their petitions is not relevant under this factor. For this reason, we determine that the second *General Plastic* factor does not weigh in favor of denial.

c. Whether at the time of filing of the second petition the petitioner already received the patent owner’s preliminary response to the first petition or received the Board’s decision on whether to institute review in the first petition

As to the third *General Plastic* factor, Patent Owner argues that Petitioner “had the benefit of the preliminary responses filed in the Sandvine IPRs (which were filed in the first half of 2017) as well as the Board’s analysis in those same IPRs (which issued in July 2017).” Prelim. Resp. 37. Even so, we determine that Patent Owner has not shown persuasively that this factor weighs in favor of denial.

The third *General Plastic* factor is designed to prevent a challenger from using the Patent Owner’s preliminary response as a guide for formulating a subsequent challenge. *See Toyota Motor Corp. v. Cellport Sys., Inc.*, IPR2015-01423, Paper 7 at 8 (PTAB Oct. 28, 2015) (“[T]he opportunity to read Patent Owner’s Preliminary Response in IPR2015-00634, prior to filing the Petition here, is unjust.”). Here, even though

Patent Owner filed a preliminary response in IPR2017-00451, Patent Owner presents no analysis supporting a reasonable inference that Petitioner used that preliminary response as a guide for formulating the arguments in this Petition. Thus, we determine that the third *General Plastic* factor does not weigh in favor of denial.

d. The length of time that elapsed between the time the petitioner learned of the prior art asserted in the second petition and the filing of the second petition; Whether the petitioner provides adequate explanation for the time elapsed between the filings of multiple petitions directed to the same claims of the same patent

Patent Owner argues that the fourth and fifth *General Plastic* factors weigh in favor of denial, because Petitioner “knew of the primary art raised in this Petition for at least nine years” and fails to “explain the twelve months that lapsed between [Petitioner’s] knowledge of the challenged patent . . . and the filing of the instant petition.” Prelim. Resp. 37. Again, we determine these factors do not weigh in favor of exercising our discretion to deny institution. Even if Petitioner could have filed its Petition earlier, “we have no reason to believe, on this record, that Petitioner *delayed* by filing when it did, or that Petitioner gained any particular advantage by filing when it did.” *Samsung Elecs. Co. v. Immersion Corp.*, IPR2018-01499, Paper 11 at 20–21 (PTAB Mar. 6, 2019). For example, Patent Owner has not pointed to any particular advantage enjoyed by Petitioner by its alleged delay.

e. The finite resources of the Board; The requirement under 35 U.S.C. § 316(a)(11) to issue a final determination not later than 1 year after the date on which the Director notices institution of review

Patent Owner argues that the sixth and seventh *General Plastic* factors weigh in favor of denial given challenges related to the “ongoing COVID-19 pandemic” as well as “the ongoing investment in two district court litigations involving the same challenged patents and asserted art.” Prelim. Resp. 37–38. Having considered Patent Owner’s arguments, we determine that the sixth and seventh *General Plastic* factors do not weigh in favor of denying institution. “[T]he intent of the [sixth] factor . . . is to conserve *Board* resources from repeat or multiple staggered petitions challenging the same claims of the same patent before the Board.” *Samsung* at 17. And here, this proceeding is not part of a series of multiple, staggered proceedings, but rather is the only challenge to the ’751 patent that Petitioner filed. Moreover, as explained above, we find that it is more likely that the District Court will incur delays due to the COVID-19 pandemic than the Board. *See supra* § II.A.1.b.

f. Weighing the Factors

For the reasons discussed above, we determine that all the factors in this particular case do not weigh in favor of exercising our discretion under 35 U.S.C. § 314(a). Therefore, we decline Patent Owner’s request to deny the Petition under 35 U.S.C. § 314(a) for reason of serial petitions.

B. Obviousness – Principles of Law

A claim is unpatentable under 35 U.S.C. § 103(a) if the differences between the claimed subject matter and the prior art are such that the subject matter, as a whole, would have been obvious at the time of the invention to a person having ordinary skill in the art. *KSR Int’l Co. v. Teleflex Inc.*, 550

U.S. 398, 406 (2007). The question of obviousness is resolved on the basis of underlying factual determinations, including (1) the scope and content of the prior art; (2) any differences between the claimed subject matter and the prior art; (3) the level of ordinary skill in the art; and (4) objective evidence of obviousness or non-obviousness, if present. *See Graham*, 383 U.S. at 17–18. When evaluating a claim for obviousness, we also must “determine whether there was an apparent reason to combine the known elements in the fashion claimed by the patent at issue.” *KSR*, 550 U.S. at 418 (citing *In re Kahn*, 441 F.3d 977, 988 (Fed. Cir. 2006)).

C. Level of Ordinary Skill in the Art

To determine whether an invention would have been obvious at the time it was made, we consider the level of ordinary skill in the pertinent art at the time of the invention. *Graham v. John Deere Co.*, 383 U.S. 1, 17 (1966). In assessing the level of ordinary skill in the art, various factors may be considered, including the “type of problems encountered in the art; prior art solutions to those problems; rapidity with which innovations are made; sophistication of the technology; and educational level of active workers in the field.” *In re GPAC Inc.*, 57 F.3d 1573, 1579 (Fed. Cir. 1995) (quoting *Custom Accessories, Inc. v. Jeffrey-Allan Indus., Inc.*, 807 F.2d 955, 962 (Fed. Cir. 1986)). “[O]ne or more factors may predominate.” *Id.*

Petitioner copies the Board’s previous preliminary finding for the level of ordinary skill in the art and argues that one of ordinary skill in the art at the time of the invention of the ’751 patent would have “had a bachelor’s degree in electrical engineering, computer engineering, computer science, or a related field (or its equivalent), and one to two years of experience working in networking environments, including at least some experience with network traffic monitors and/or analyzers.” Pet. 7–8 (citing

Ex. 1056 (IPR2017-00450 Institution Decision), 13–14; Ex. 1006 ¶¶ 195–201).

Patent Owner proposes a different definition for the level of ordinary skill in the art, but Patent Owner provides no reasoning to deviate from the Board’s earlier preliminary finding. Prelim. Resp. 21–22. Based on this record, we adopt Petitioner’s articulation of the level of skill in the art (i.e., the level determined in the IPR2017-00450 Institution Decision), which is consistent with the ’751 patent and the asserted prior art, and we apply it in our obviousness evaluations below.

D. Claim Construction

Because the Petition was filed after November 13, 2018, we construe the challenged claims by applying “the standard used in federal courts, in other words, the claim construction standard that would be used to construe the claim in a civil action under 35 U.S.C. [§] 282(b), which is articulated in *Phillips [v. AWH Corp.]*, 415 F.3d 1303 (Fed. Cir. 2005) (en banc).”¹⁰ Under *Phillips*, the words of a claim are generally given their “ordinary and customary meaning,” which is the meaning they would have to a person of ordinary skill in the art at the time of the invention, in light of the specification and prosecution history. *See Phillips*, 415 F.3d at 1312–13.

Petitioner submits the following claim terms for construction:

(i) “conversational flow(s)”; (ii) “the flow”/”new flow”/”existing flow”; and (iii) “flow-entry database.” Pet. 8–16. As to the remaining claim terms, Petitioner argues that they should be afforded their plain and ordinary meaning. *Id.* at 16. Patent Owner disputes Petitioner’s proposed

¹⁰ Changes to the Claim Construction Standard for Interpreting Claims in Trial Proceedings Before the Patent Trial and Appeal Board, 83 Fed. Reg. 51,340, 51,343–44 (Oct. 11, 2018) (codified at 37 C.F.R. pt. 42).

construction for “conversational flow”/”conversational flow-sequence,” while not submitting any other terms for construction. Prelim. Resp. 22–26.

1. “conversational flow(s)”

In prior *inter partes* review proceedings involving the ’751 patent and related patents, the Board preliminarily construed “conversational flow” as “the sequence of packets that are exchanged in any direction as a result of an activity (for instance, the running of an application on a server as requested by a client), where some conversational flows involve more than one connection, and some even involve more than one exchange of packets between a client and a server.” *See, e.g.*, IPR2017-00451, Paper 8 at 9–10 (PTAB July 26, 2017) (Ex. 1057).¹¹ The same construction—with only non-substantive punctuation changes—was also adopted by the district court in *Packet Intelligence LLC v. NetScout Sys., Inc.*, No. 2:16-cv-230 (E.D. Tex.) and *Packet Intelligence LLC v. Sandvine Corp.*, No. 2:16-cv-00147 (E.D. Tex.).¹²

While acknowledging the Board’s prior construction, Petitioner contends that the Board nevertheless should apply a narrower construction in

¹¹ The Board also preliminarily adopted the same construction in IPR2017-00450, Paper 8 at 9–10 (PTAB July 26, 2017) (Ex. 1056); IPR2017-00629, Paper 8 at 9 (PTAB July 26, 2017) (Ex. 1058); IPR2017-00630, Paper 9 at 9 (PTAB July 26, 2017) (Ex. 1059); IPR2017-00769, Paper 8 at 10 (PTAB July 26, 2017) (Ex. 1060); and IPR2017-00862, Paper 8 at 9–10 (PTAB July 26, 2017) (Ex. 1061).

¹² *See, e.g., Packet Intelligence LLC v. NetScout Sys., Inc.*, No. 2:16-cv-230, Dkt. No. 66 at 6 (E.D. Tex. Mar. 15, 2017) (Ex. 1067) (construing “conversational flow” as “the sequence of packets that are exchanged in any direction as a result of an activity—for instance, the running of an application on a server as requested by a client—and where some conversational flows involve more than one connection, and some even involve more than one exchange of packets between a client and server”).

this proceeding than in the prior proceedings because this is the first time the Board will construe the claims under the *Phillips* standard, as opposed to the broadest reasonable interpretation standard. Pet. 8. Under the *Phillips* standard, Petitioner contends, “conversational flow” should be construed as “the sequence of packets that are exchanged in any direction as a result of specific software program activity, where such packets form multiple connection flows that are linked based on that activity.” *Id.* at 8–9. In support of this construction, Petitioner asserts that Patent Owner has argued in prior *inter partes* review proceedings and prior district court proceedings that a conversational flow is “based on specific software program activity.” *Id.* at 9–10. Regardless of these contentions, however, Petitioner further contends that “[t]he prior art invalidates the Challenged Claims under [either] Petitioner’s or Patent Owner’s proposed construction.” *Id.* at 12.

Patent Owner responds that “Petitioner[] present[s] no compelling reason to deviate from the previous constructions,” which, Patent Owner contends, “stem from the specification’s express definition of the term.” Prelim. Resp. 22–23 (citing Ex. 1001, 2:37–45 (“A conversational flow, on the other hand, is the sequence of packets that are exchanged in any direction as a result of an activity—for instance, the running of an application on a server as requested by a client. . . . [And] some conversational flows involve more than one connection, and some even involve more than one exchange of packets between a client and server.”)).¹³

¹³ Notwithstanding Patent Owner’s contention, the quoted “definition” does not appear in the specification of the ’751 patent, but rather in related U.S. Patent No. 6,651,099 (Ex. 1001). We note, however, that U.S. Patent Application Serial No. 09/608,237, the application from which the ’099 patent issued, is incorporated by reference in the ’751 patent. *See* Ex. 1004, 1:17–20.

Patent Owner further contends Petitioner misinterprets statements made in previous proceedings and takes them out of context to advance an improper construction of “conversational flow.” *Id.* at 23–24. As argued by Patent Owner, each of the statements highlighted by Petitioner, when viewed in context, follows the definition of “conversational flow” provided in the specification and adopted by both the Board and the district court in prior proceedings. *Id.* at 24; *see also id.* at 25–26.

Having considered the parties’ respective arguments, we are not persuaded at this stage of the proceeding by Petitioner’s contentions that Patent Owner’s statements in the prior Board proceedings or in the district court proceedings warrant limiting the term to sequences resulting from “specific software” activity. At the same time, however, we also do not see any reason to include the additional phrases of the prior Board and district court constructions—i.e., “(for instance, the running of an application on a server as requested by a client), where some conversational flows involve more than one connection, and some even involve more than one exchange of packets between a client and a server”—all of which we regard as merely exemplary and non-limiting. We do not understand the inclusion of those phrases to, for example, exclude from the construction flows involving only a single connection or flows that involve only a single exchange of packets. *See Prelim. Resp.* 24–25 (“[A]s the specification teaches, not all ‘conversational flows’ *necessarily* include multiple related connections—some conversations may entail only a single connection.”). Accordingly, to the extent necessary for purposes of this Decision, we preliminarily construe “conversational flow,” as “sequence of packets that are exchanged in any direction as a result of an activity.”

2. *Other claim terms*

We conclude that no express claim construction is necessary for any other claim terms at this stage of the proceeding. *See, e.g., Nidec Motor Corp. v. Zhongshan Broad Ocean Motor Co.*, 868 F.3d 1013, 1017 (Fed. Cir. 2017) (quoting *Vivid Techs., Inc. v. Am. Sci. & Eng’g, Inc.*, 200 F.3d 795, 803 (Fed. Cir. 1999)) (“[W]e need only construe terms ‘that are in controversy, and only to the extent necessary to resolve the controversy.’”).

E. Ground 1: Obviousness over Riddle and Ferdinand

Petitioner argues that the combination of Riddle and Ferdinand renders the challenged claims obvious under 35 U.S.C. § 103(a). Pet. 17–77.

1. *Overview of Riddle*

Riddle describes a method for automatically classifying packet flows for use in allocating bandwidth resources by a rule of assignment of a service level. Ex. 1008, 4:6–10. The method comprises applying individual instances of traffic classification paradigms to packet network flows based on selectable information obtaining from layers of a multi-layered communication protocol in order to define a characteristic class, then mapping the flow to the defined traffic class. *Id.* at 4:10–15. Figure 3 is reproduced below.

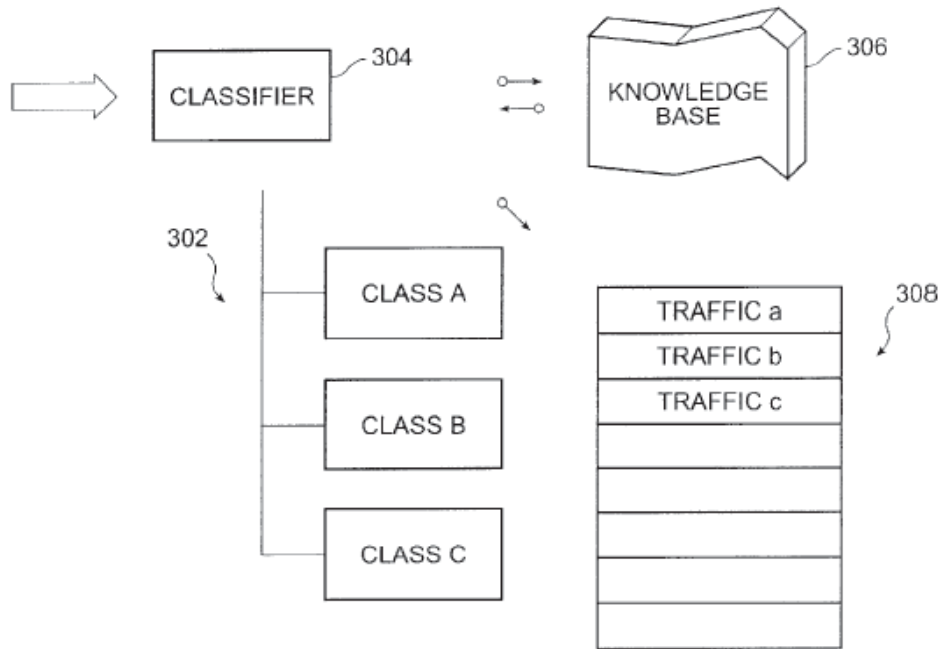

FIG. 3

Figure 3 illustrates a system for automatically classifying traffic. Ex. 1008, 12:27–28. A traffic tree 302 classifies new traffic under a particular member class node. *Id.* at 12:28–30. A traffic classifier 304 detects services for incoming traffic. *Id.* at 12:30–31. A knowledge base 306 contains heuristics for determining traffic classes. *Id.* at 12:32–33. A plurality of saved lists 308 stores classified traffic pending incorporation into the traffic tree 302. *Id.* at 12:37–38.

Figure 4A is reproduced below.

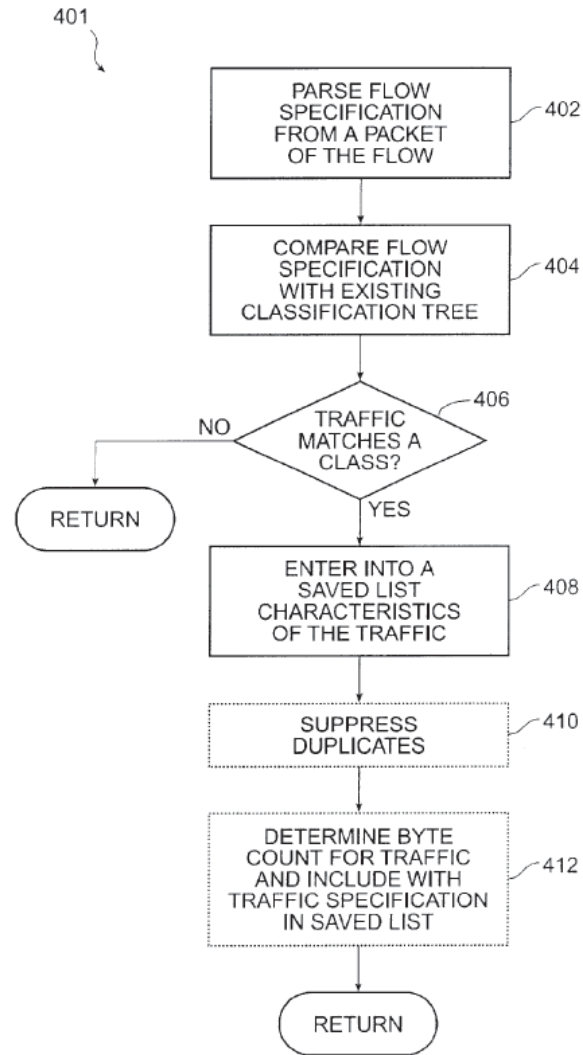

FIG. 4A

Figure 4A illustrates a flowchart 401 of processing steps for automatically classifying traffic. Ex. 1008, 12:42–43. In a step 402, a flow specification is parsed from the flow being classified. *Id.* at 12:43–44. Then in a step 404, the flow specification parsed from the flow in step 402 is compared with the traffic specifications in each node of the classification tree. *Id.* at 12:44–47. In a decisional step 406, a determination is made of whether traffic matches one of the classes being classified. *Id.* at 12:48–50. If this is so, then in a step 408, an entry is made in a list of identifying

characteristics, such as protocol type, IP protocol number, server port, traffic type, MIME type, or time of occurrence of traffic. *Id.* at 12:50–53.

Figure 4B is reproduced below.

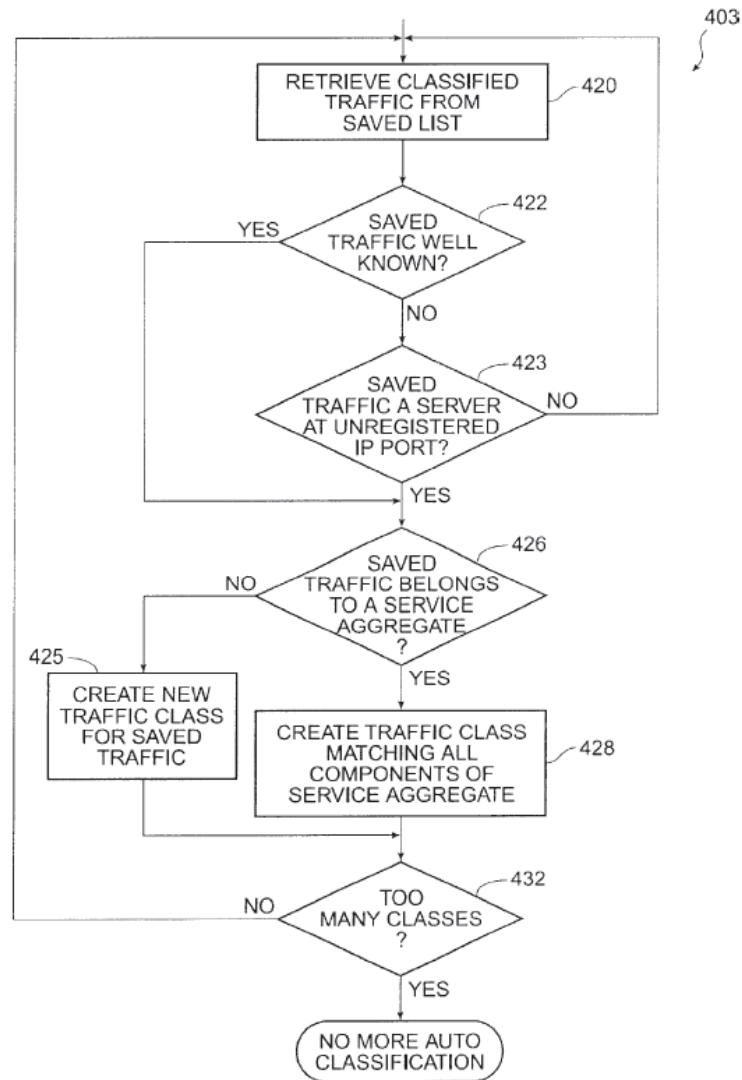

FIG. 4B

Figure 4B illustrates a flowchart 403 of the processing steps for integrating traffic classes into a classification tree. Ex. 1008, 13:36–38. In a step 420, an instance of saved traffic is received from a saved traffic list 308. *Id.* at 13:40–42. Next, in a decisional step 422, the instance of saved traffic is examined to determine whether it is well-known and a name representing

its type exists. *Id.* at 13:42–45. If this is so, then processing continues with a test of whether the saved traffic belongs to a service aggregate in step 426. *Id.* at 13:45–47. Otherwise, in a step 423, the instance of saved traffic is examined to determine whether it appears to be a server connection port of an unregistered IP port. *Id.* at 13:47–50. If this is not so, then processing continues with the next traffic class in the saved list in step 420. *Id.* at 13:51–52. In decisional step 426, the instance of saved traffic is examined to determine whether it belongs to a service aggregate. *Id.* at 13:52–54. If the traffic does belong to a service aggregate, then, in a step 428, a traffic class is created which will match all components of the service aggregate. *Id.* at 13:57–59. In a further step 425, a new traffic class is created to match the instance of saved traffic. *Id.* at 13:59–62.

2. *Overview of Ferdinand*

Ferdinand, titled “Network Monitoring,” relates to “monitoring and managing communication networks for computers.” Ex. 1009, code (54), 1:3–4. Ferdinand discloses a monitoring system with “a Network Monitor 10 and a Management Workstation 12.” *Id.* at 11:32–12:1. In monitoring the network, Ferdinand indicates that a “statistical object represents a network parameter for which performance information is gathered,” and that Monitor 10 keeps information about monitored statistical objects in “Statistics Module (STATS) 36.” *Id.* at 22:18–22. STATS 36 is a database (*id.* at 19:5–11) and “defines the database and it contains subroutines for updating the statistics which it keeps” (*id.* at 28:14–15). Examples of data the database stores include records “per ip address,” “per ip pair,” “per udp pair,” “per ftp control connection,” and “per ftp data connection.” *Id.* at 29:3–30:7.

3. *Independent Claims 1 and 17*

- a. *“A method of analyzing a flow of packets passing through a connection point on a computer network, the method comprising:” (claim 1) / “A packet monitor for examining packets passing through a connection point on a computer network, each packets [sic] conforming to one or more protocols, the monitor comprising:” (claim 17)*

Petitioner argues that Riddle teaches the preamble elements of claims 1 and 17. Pet. 27 (citing Ex. 1006 ¶¶ 263–269, 618–623, 765, 840, 841); *id.* at 27–31. In particular, Petitioner contends, Riddle describes a classifier, operating in a network-connected computer system (e.g., in a server acting as a packet monitor and a network interface acting as a packet acquisition device), that parses and examines (or analyzes) traffic flow packets passing through a network. *Id.* at 27–28 (citing Ex. 1008, code (57), 1:57–61, 3:67–4:2, 4:6–17, 5:53–67, 12:27–41, 13:30–31, 14:22–40, Figs. 1A, 1B, 3; Ex. 1006 ¶¶ 263, 264). Regarding “connection point[s],” Petitioner contends, “the ’751 [p]atent acknowledges that these are simply the points where the packet monitor connects to the network,” and Riddle “details that its packet monitor connects to [a] network connection . . . via a system gateway to analyze passing-through packets.” *Id.* at 29 (citing Ex. 1004, 5:65–6:19, Fig. 1; Ex. 1008, 5:53–67, 6:9–15, 7:21–24, Figs. 1A, 1B; Ex. 1006 ¶ 265). Further, Petitioner contends, “[f]or networks connecting multiple clients and servers . . . , Riddle teaches examining packets via ‘network routing means’ and/or routers.” *Id.* (citing Ex. 1008, 7:10–34, Figs. 1C, 3; Ex. 1006 ¶ 266). Still further, Petitioner contends that “Riddle analyzes packets in real-time to manage network bandwidth based on flow classification,” that “[Riddle]’s monitor determines a packet’s traffic class, e.g., Real Time Protocol,” and that “Riddle also teaches allocating

bandwidth based on information ascertainable from multiple OSI layers of each flow, i.e., based on analyzing the flow of packets passing through a network's connection point.” *Id.* at 30 (citing Ex. 1008, code (57), 1:54–61, 2:4–13, 2:66–67, 3:32–39, 3:67–4:2, 4:6–9, 10:57–59, 12:3–12; Ex. 1006 ¶¶ 267, 268).

Patent Owner does not challenge Petitioner's contentions with respect to these preamble recitations in its Preliminary Response, and we are persuaded, on the current record, that Petitioner provides adequate evidence to support its contentions.

- b. *“(a) receiving a packet from a packet acquisition device coupled to the connection point;” (claim 1) / “(a) a packet acquisition device coupled to the connection point and configured to receive packets passing through the connection point;” (claim 17)*

Petitioner argues that Riddle teaches elements (a) of claims 1 and 17. Pet. 31 (citing Ex. 1006 ¶¶ 624–626, 766, 820–824, 842); *id.* at 31–32. In particular, Petitioner identifies various “packet acquisition devices coupled to a connection point” in Riddle, including network interface 40 connected to the system gateway depicted in Riddle's Figures 1A and 1B, as well as the “network routing means” and router 75 depicted in Riddle's Figure 1C. *Id.* at 31 (citing Ex. 1008, 6:5–15, 7:21–24, 16:54–17:15 (claim 8), Figs. 1A–1C; Ex. 1006 ¶¶ 264–266). Citing disclosure in Riddle describing “automatically classify[ing] packet flows to help allocate bandwidth resources” and “to classify a complete enumeration of the possible traffic,” and further relying on U.S. Patent No. 6,046,980 to Packer (Ex. 1031), incorporated by reference in Riddle,¹⁴ and the testimony of Dr. Weissman,

¹⁴ See Ex. 1008, 1:29–31, 1:37–41.

Petitioner contends that a person of ordinary skill in the art “would have understood that, in order to classify packet flows, Riddle’s acquisition device receives packets.” *Id.* at 32 (citing Ex. 1008, code (57), 4:7–17, 4:55–60; Ex. 1006 ¶¶ 482, 486, 626; Ex. 1031, 4:12–16).

Patent Owner does not challenge Petitioner’s contentions with respect to these limitations in its Preliminary Response, and we are persuaded, on the current record, that Petitioner provides adequate evidence to support its contentions.

- c. *“(b) for each received packet, looking up a flow-entry database for containing one or more flow-entries for previously encountered conversational flows, the looking up to determine if the received packet is of an existing flow,” (claim 1) / “(b) a memory for storing a database for containing one or more flow-entries for previously encountered conversational flows to which a receive packet may belong,” (claim 17)*

Petitioner contends that Riddle in view of Ferdinand renders elements (b) of claims 1 and 17 obvious, based on Riddle’s disclosure of flow-entry lists that may be stored in databases, such as those disclosed by Ferdinand. Pet. 33 (citing Ex. 1006 ¶¶ 328–339, 767–769, 843); *id.* at 33–47. According to Petitioner, “Riddle looks up flow-entries based on service aggregates or PointCast flows, which both meet the claimed ‘previously encountered conversational flows.’” *Id.* at 33. With respect to reasons to combine the teachings of Riddle and Ferdinand, Petitioner contends that “Riddle and Ferdinand are in the same field of endeavor,” “contain overlapping disclosures with similar purposes,” and illustrate that it was well-known and ubiquitous in the art for networking devices to include database storage structures and distinct processing engines. *Id.* at 25 (citing Ex. 1008, 4:7–17, 9:14–27, 12:37–59, Figs. 3, 4A, 4B; Ex. 1009, 12:3–9;

Ex. 1006 ¶¶ 256, 257, 764). Relying on the testimony of Dr. Weissman, Petitioner contends that a person of ordinary skill in the art “would have been motivated and found it obvious to store Riddle’s hierarchical classification trees and flow-entries in a database such as the database taught by Ferdinand,” including to provide increased functionality (e.g., searching, analyzing, and modifying the flow-entries), to allow multiple network operators to access classification information simultaneously, and in accordance with “Riddle’s desired goal of managing data entries to determine whether the examined packets belong to a service aggregate, such as an FTP session.” *Id.* at 26 (citing Ex. 1008, 11:9–24, 12:34–35, 12:65–13:7; Ex. 1009, 41:32–42:3, 44:8–14, 47:3–48:11; Ex. 1006 ¶ 259).

In the Preliminary Response, Patent Owner contends that Riddle fails to disclose the recited “conversational flows” under either of the proposed constructions of that term. Prelim. Resp. 38–44. According to Patent Owner, “[a]ll of the proposed constructions relate a ‘conversational flow’ to an ‘activity’” such as “the running of an application on a server as requested by a client,” whereas “Riddle’s traffic classes correlate traffic according to whether it matches a given specification” and, thus, “[a]t best . . . relate to a multitude of activities.” *Id.* at 38 (citing Ex. 1001, 2:39–40).

According to Patent Owner, the specification teaches that an “activity” is, “for instance, the running of an application on a server as requested by a client.” Prelim. Resp. 38 (citing Ex. 1001, 2:39–40). As an example, Patent Owner asserts that “[a] client running Skype to conduct a call is an example of an ‘activity.’” *Id.* at 39. Further, according to Patent Owner, among three simultaneous Skype calls, “[e]ach call is a separate activity, but all the activities stem from the same application.” *Id.* at 40.

Patent Owner proceeds to extend its Skype example to the portions of Riddle discussed in the Petition relative to this element. *Id.* at 41–44.

Patent Owner contends that neither Riddle’s “service aggregates” nor its recognition of “PointCast” traffic cited by Petitioner discloses the recited “conversational flow.” Prelim. Resp. 40.

With respect to Riddle’s service aggregates, Patent Owner asserts that “a service aggregate is essentially a ‘set’ of . . . traffic classes.” Prelim. Resp. 42. Patent Owner posits that a service aggregate could be created to match Skype traffic, but that such a service aggregate would not recognize the presence of three different conversation flows among three simultaneous Skype calls. *Id.* According to Patent Owner, the ’751 patent “distinguishes between the three different Skype conversations because each one is a different ‘activity.’” *Id.*

Similarly, with respect to Riddle’s disclosure of PointCast traffic, Patent Owner asserts that “Riddle’s purported ability to recognize PointCast traffic as showing that Riddle recognizes ‘conversational flows’” is “merely a specific example of using one of Riddle’s traffic classes—namely one for PointCast.” Prelim. Resp. 43. Patent Owner asserts that under this teaching of Riddle, “[a]ll PointCast traffic activities would be lumped together, rather than recognizing that each different client using PointCast represents a different ‘activity’ as specified by the claims.” *Id.* Patent Owner concludes that “the specification teaches that different activities of the same type, but by different clients, yield different conversational flows” and, therefore, Riddle’s PointCast traffic recognition fails to disclose the claimed “conversational flows.” *Id.* at 43–44 (citing Ex. 1001, 3:4–6).

We agree generally with Patent Owner’s assertion that the claims tie “conversational flow” to an activity. *See supra* § II.D.1 (preliminarily

construing “conversation flow” as “sequence of packets that are exchanged in any direction as a result of an *activity*” (emphasis added)). But Patent Owner does not persuade us, on this record, that the examples presented as a “multitude of activities” cannot instead represent an “activity.” That Patent Owner provides examples from the specification of an “activity” that suggest particularized sets of actions correspond to an activity does not exclude other larger sets of actions from also corresponding to an activity. We are persuaded that Petitioner presents sufficient evidence that would support a finding that either of Riddle’s disclosures of service aggregates or PointCast traffic teaches or suggests an activity in the context of a conversational flow. Accordingly, having considered the parties’ respective arguments, we are persuaded that Petitioner has sufficiently established that Riddle teaches the recited limitations.

d. “a conversational flow including an exchange of a sequence of one or more packets in any direction between two network entities as a result of a particular activity using a particular layered set of one or more network protocols, a conversational flow further having a set of one or more states, including an initial state;” (claims 1, 17)

Petitioner argues that Riddle teaches “a conversational flow . . . having a set of one or more states, including an initial state,” as recited in claim 1. Pet. 49.

First, Petitioner argues that Riddle teaches a monitor that “classifies flows by ‘a series of steps through a traffic class tree.’” Pet. 49 (citing Ex. 1008, 9:20–25; Ex. 1006 ¶ 129). According to Petitioner, “[s]uch class trees are a common data classification structure,” which include flow states. *Id.* (citing Ex. 1006 ¶ 348). Riddle’s Figure 2A, shown below as annotated

by Petitioner, illustrates an exemplary classification tree. Ex. 1008, 4:43–44; *see also* Pet. 51 (annotating Ex. 1008, Fig. 2A).

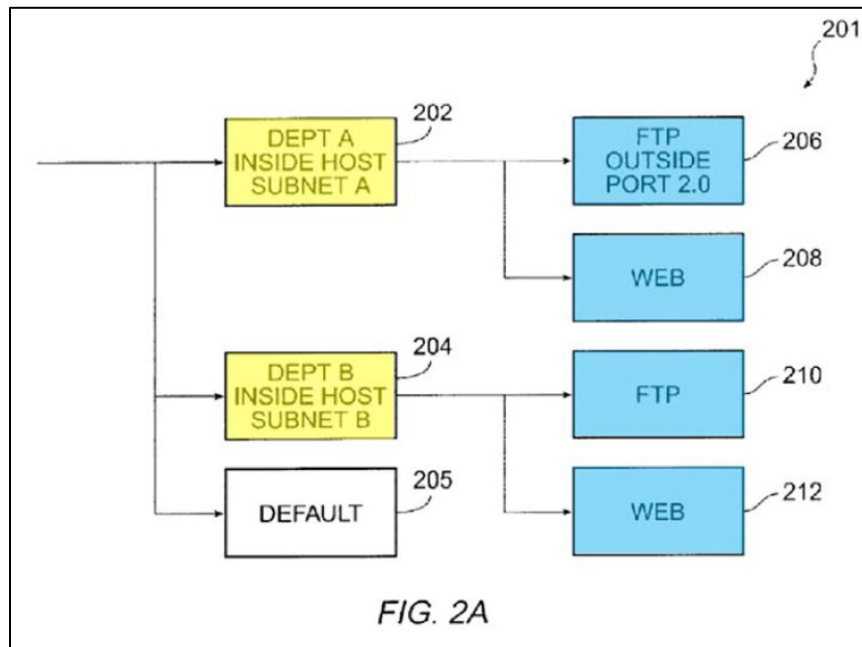

Figure 2A depicts a “representative division[] of bandwidth,” in accordance with Riddle’s teachings. Ex. 1008, 4:43–44. Petitioner argues that Riddle teaches department checks (shown in yellow). Pet. 50. More specifically, Petitioner argues that Riddle’s “classifier[, *inter alia*,] initially tests if the flow is intended for Department B (204) by comparing the packet’s source (client) IP to the range of IP addresses defined for subnet B.” *Id.* (citing Ex. 1008, 10:19–39; Ex. 1006 ¶ 349). If so, the classifier proceeds to the next step (shown in blue) to test if the flow is for File Transfer Protocol (“FTP”) (210), according to Petitioner. *Id.*

Petitioner also argues that Riddle teaches displaying a hierarchical classification tree that lists state operations related to FTP (e.g., to host 1, tcp, and FTP). Pet. 57 (citing Ex. 1008, 13:11–22; Ex. 1006 ¶¶ 351, 780, 781). According to Petitioner, one of ordinary skill in the art would have

understood that this hierarchy involves state operations. *Id.* (citing Ex. 1006 ¶¶ 351, 781).

Lastly, Petitioner cites Packer (which Riddle incorporates by reference) to argue that Packer “describes traversing a set of predefined states by recursively processing through matching child-class definitions.” *Id.* at 52–53 (citing Ex. 1008, 1:38–44; Ex. 1031, 18:1–26, Fig. 5F; Ex. 1006 ¶ 777).

Patent Owner does not challenge Petitioner’s contentions with respect to these limitations in its Preliminary Response, except to the extent Patent Owner generally contends Riddle does not teach “conversational flows” (*see supra* § II.E.3.c), and we are persuaded, on the current record, that Petitioner provides adequate evidence to support its contentions that the combination teaches this limitation.

- e. “(c) an analyzer subsystem coupled to the packet acquisition device configured to lookup for each received packet whether a received packet belongs to a flow-entry in the flow-entry database” (claim 17)

Referring back to its arguments with respect to elements 1(a), 1(b), 17(a), and 17(b) (*see supra* §§ II.E.3.b., II.E.3.c), Petitioner contends that Riddle alone or in view of Ferdinand renders obvious a packet acquisition device configured to look up whether a received packet belongs to a flow-entry in the flow-entry database. Pet. 54 (citing Ex. 1006 ¶¶ 340–344, 649–653, 766–769, 842, 843, 845). For example, according to Petitioner, Figure 4B of Riddle shows that “Riddle looks up whether a flow matches a traffic class in relation to classifying a service aggregate based on a plurality of indicators,” while steps 410 and 412 of Riddle’s Figure 4A shows that “Riddle checks if the flow is a new flow or an existing flow.” *Id.* (citing Ex. 1008, 12:53–60, 13:42–47, Figs. 4A, 4B; Ex. 1006 ¶¶ 132, 342).

Further, Petitioner contends, Riddle discloses the recited “analyzer subsystem,” citing Riddle’s disclosure of “a processor means operative to: parse a packet into a first flow specification.” *Id.* at 55 (quoting Ex. 1008, 16:61–62 (claim 8)). According to Petitioner, “Riddle’s processor has programming code for performing lookup functions, and performs the function of matching a parsed flow specification to a traffic class” and “Riddle’s Figure 1A shows that its system includes processor 30 coupled to memory subsystem 35.” *Id.* (citing Ex. 1008, 5:53–57, 6:1–15, 16:54–17:15 (claim 8), Fig. 1A; Ex. 1006 ¶¶ 343, 409).

Patent Owner does not challenge Petitioner’s contentions with respect to this limitation in its Preliminary Response, and we are persuaded, on the current record, that Petitioner provides adequate evidence to support its contentions.

- f. “(c) if the packet is of an existing flow, identifying the last encountered state of the flow, performing any state operations specified for the state of the flow, and updating the flow-entry of the existing flow including storing one or more statistical measures kept in the flow-entry; and” (claim 1) / “[an analyzer subsystem configured] to update the flow-entry of the existing flow including storing one or more statistical measures kept in the flow-entry in the case that the packet is of an existing flow, and” (claim 17)*

Referring back to its arguments with respect to the “conversational flow” elements discussed in subsection II.E.3.d. above, Petitioner contends that “Riddle teaches performing state operations of determining statistical metrics such as duplicate count, most recent encounter with traffic with same identifying characteristics, and byte count.” Pet. 56 (citing Ex. 1008, 12:42–13:8, 14:1–5, Fig. 4A; Ex. 1006 ¶¶ 778, 779). According to Petitioner, “Riddle further teaches identifying and storing such metrics for

existing conversation flows.” *Id.* (citing Ex. 1008, 12:56–57, Fig. 4A). Further, Petitioner contends, Riddle describes displaying a hierarchical classification tree that shows state operations related to FTP, and a person of ordinary skill in the art would have understood that transitioning from one class to the next in Riddle’s hierarchy involves state operations. *Id.* at 57 (citing Ex. 1008, 13:11–22; Ex. 1006 ¶¶ 351, 780, 781). Petitioner argues that Riddle’s Figure 4A “describes analyzing information identifying the characteristics of the traffic as the classifier parses the flow’s packets and matching the parsed packets to a class.” *Id.* (citing Ex. 1008, 12:42–48). According to Petitioner, “Riddle’s classifier advances through the sequence of packets of a particular flow to parse and classify those packets” in accordance with the classification tree, “result[ing] in Riddle’s classifier performing a corresponding state operation at each node to update the identifying characteristics of the flow.” *Id.* (citing Ex. 1006 ¶ 782). According to Petitioner, Riddle thus teaches the recited elements because Riddle’s monitor identifies the last encountered state of the flow and performs any state operations specified for the state of the flow for existing flows. *Id.* at 57–58 (citing Ex. 1008, 12:53–13:8, 13:42–47, 14:1–5, 16:40–48 (claim 5), Figs. 4A, 4B; Ex. 1006 ¶¶ 778–783, 846).

Patent Owner does not challenge Petitioner’s contentions with respect to these limitations in its Preliminary Response, except to the extent Patent Owner generally contends Riddle does not teach “conversational flows” (*see supra* § II.E.3.c), and we are persuaded, on the current record, that Petitioner provides adequate evidence to support its contentions.

- g. “[*Id*] if the packet is of a new flow, performing any state operations required for the initial state of the new flow and storing a new flow-entry for the new flow in the flow-entry database, including storing one or more statistical measures kept in the flow-entry,” (claim 1) / “an analyzer subsystem configured “to store a new flow-entry for the new flow in the flow-entry database, including storing one or more statistical measures kept in the flow-entry if the packet is of a new flow” (claim 17)

Referring back to its arguments with respect to elements 1(b), 1(c), 17(b), 17(c), and the “conversational flow” elements discussed in subsections II.E.3.c.–f. above, Petitioner contends that Riddle alone or in view of Ferdinand renders these elements obvious. Pet. 58–59. In particular, Petitioner contends that, “[f]or new flow-entries, Riddle discloses the state operation of creating a new flow-entry such as Figure 4A’s step 408 and new class in Figure 4B’s step 425 for service aggregate classes.” *Id.* at 58. Relying on Dr. Weissman’s testimony, Petitioner contends that a person of ordinary skill in the art “would have understood that Riddle’s creation of a new flow-entry and a new class are examples of state operations for the initial state of the newly encountered conversational flow.” *Id.* (citing Ex. 1006 ¶¶ 780, 784–786). According to Petitioner, for new flow-entries, “Riddle teaches performing state operations of determining statistical metrics such as duplicate count, most recent encounter with traffic with same identifying characteristics, and byte count.” *Id.* (citing Ex. 1008, 12:42–13:8, 14:1–5, Fig. 4A; Ex. 1006 ¶¶ 778, 779). Petitioner further contends that “Riddle discloses the state operations of updating flow-entries and determining metrics (e.g., determining whether flow matches a traffic class in relation to classifying a service aggregate, duplicate count, most recent encounter with traffic with same identifying

characteristics, and byte count),” and that “these metrics are stored in the saved list.” *Id.* at 58–59 (citing Ex. 1008, 12:30–59). Petitioner argues that the ’751 patent and related patents “acknowledge that determining metrics is a state operation,” and, relying on Dr. Weissman’s testimony, that a person of ordinary skill in the art would have understood that each of such state operations “is an example of state operations for the initial state of a new conversation.” *Id.* at 59 (citing Ex. 1006 ¶¶ 770–783, 787, 788), 59 n.184.

Patent Owner does not challenge Petitioner’s contentions with respect to these limitations in its Preliminary Response, except to the extent Patent Owner generally contends Riddle does not teach “conversational flows” (*see supra* § II.E.3.c), and we are persuaded, on the current record, that Petitioner provides adequate evidence to support its contentions.

h. “wherein every packet passing though the connection point is received by the packet acquisition device, and” (claim 1)

Petitioner contends Riddle discloses this claim element. Pet. 59–61 (citing Ex. 1006 ¶¶ 266–268, 270–276, 624–626, 789–794; Ex. 1008, 4:1–2, 4:16–17, 6:5–15, 7:21–34, 10:52–11:9, 12:30–41, 12:50–59, 13:1–31, 13:59–60, 16:54–17:15 (claim 8), Figs. 1A–1C, 3; Ex. 1031, 4:12–16, 18:58–62). Referring back to its arguments with respect to the preambles of claims 1 and 17 and elements 1(a) and 17(a), for example, Petitioner contends Riddle’s Figure 1A provides a packet monitor, as well as a packet acquisition device connected to a network connection point that provides packets to the packet monitor. *Id.* at 59–60 (citing Ex. 1008, 6:5–15, Figs. 1A, 1B). Petitioner further contends that Riddle “teaches the packet acquisition device receiving ‘every packet passing through the connection point,’” citing various portions of Riddle, Dr. Weissman’s testimony, and disclosure of Packer, incorporated by reference in Riddle, for support. *Id.*

at 60–61 (citing Ex. 1008, code (57), 4:1–2, 4:16–17, 10:52–11:9, 12:30–41, 12:50–59, 13:1–31, 13:59–60; Ex. 1006 ¶¶ 267, 268, 791–794; Ex. 1031, 4:12–16, 18:58–62).

Patent Owner does not challenge Petitioner’s contentions with respect to this limitation in its Preliminary Response, and we are persuaded, on the current record, that Petitioner provides adequate evidence to support its contentions.

- i. “wherein at least one step of the set consisting of of [sic] step (a) and step (b) includes identifying the protocol being used in the packet from a plurality of protocols at a plurality of protocol layer levels,” (claim 1) / “wherein the analyzer subsystem is further configured to identify the protocol being used in the packet from a plurality of protocols at a plurality of protocol layer levels, and” (claim 17)*

Petitioner contends Riddle specifies that each examined packet conforms to one or more protocols and details that its packet classification includes identifying the protocol being used in the packet at a plurality of protocol layer levels, thereby teaching the recited elements. Pet. 62–65 (citing Ex. 1006 ¶¶ 283–293, 795–802, 848; Ex. 1008, code (57), 1:54–57, 3:36–39, 4:7–15, 4:60–66, 7:35–8:67, 9:1–27, 9:64–65, 10:57–11:6, 12:64–13:23).

Patent Owner does not challenge Petitioner’s contentions with respect to these limitations in its Preliminary Response, and we are persuaded, on the current record, that Petitioner provides adequate evidence to support its contentions.

- j. “such that the flow-entry database is to store flow entries for a plurality of conversational flows using a plurality of protocols, at a plurality of layer levels, including levels above the network layer” (claim 1) / “wherein the database is to store flow entries for a plurality of conversational flows using a plurality of protocols, at a plurality of layer levels, including levels above the network layer” (claim 17)*

Petitioner contends that Riddle renders these claim elements obvious, either alone or in view of Ferdinand. Pet. 66 (citing Ex. 1006 ¶¶ 767–777, 803–805, 849, 850). First, referring back to its discussion of elements 1(b), 17(b), and the “conversational flow” elements, Petitioner contends Riddle discloses storing flow-entries for a plurality of conversational flows using protocol layer levels above the network layer and that Riddle alone or in view of Ferdinand renders obvious storing flow-entries in a database. *Id.* Further, Petitioner contends, “Riddle teaches identifying conversational flows for PointCast connections by relating multiple HTTP connections (application layer) with URLs that begin with ‘/FIDO-1/.’” *Id.* (citing Ex. 1008, 11:47–67). According to Petitioner, “[b]oth these examples meet the claimed ‘conversational flows using a plurality of protocols, at a plurality of layer levels, including levels above the network layer.’” *Id.* at 67.

Patent Owner does not challenge Petitioner’s contentions with respect to these limitations in its Preliminary Response, except to the extent Patent Owner generally contends Riddle does not teach “conversational flows” (*see supra* § II.E.3.c), and we are persuaded, on the current record, that Petitioner provides adequate evidence to support its contentions.

4. Dependent Claim 2

Claim 2 depends from claim 1 and further recites, “wherein step (b) includes extracting identifying portions from the packet, wherein the

extracting at any layer level is a function of the protocol being used at the layer level, and wherein the looking up uses a function of the identifying portions.” Ex. 1004, 50:61–67. Petitioner contends that Riddle discloses each of these further limitations. Pet. 67–71 (citing Ex. 1008, code (57), 1:54–57, 4:7–15, 4:60–66, 7:35–9:27, 9:64–65, 12:42–59, 13:36–62, Figs. 1D, 4A, 4B; Ex. 1006 ¶¶ 806–816).

Patent Owner does not challenge Petitioner’s contentions with respect to the further limitations of claim 2 in its Preliminary Response, and we are persuaded, on the current record, that Petitioner provides adequate evidence to support its contentions.

5. Dependent Claim 5

Claim 5 depends from claim 1 and further recites, “further including reporting one or more metrics related to the flow of a flow-entry from one or more of the statistical measures in the flow-entry.” Ex. 1004, 51:9–12. Relying on disclosure in Riddle of reporting metrics by displaying results to a network manager, Petitioner contends that Riddle teaches this further limitation. Pet. 71–72 (citing Ex. 1008, 12:64–13:1, 14:1–5; Ex. 1006 ¶¶ 817, 818).

Patent Owner does not challenge Petitioner’s contentions with respect to the further limitation of claim 5 in its Preliminary Response, and we are persuaded, on the current record, that Petitioner provides adequate evidence to support its contentions.

6. Dependent Claim 10

Claim 10 depends from claim 1 and further recites, wherein step (c) includes if the packet is of an existing flow, identifying the last encountered state of the flow and performing any state operations specified for the state of the flow starting from the last encountered state of the flow; and wherein step (d)

includes if the packet is of a new flow, performing any state operations required for the initial state of the new flow.

Ex. 1004, 51:25–31. Petitioner contends that Riddle discloses each of these further limitations, relying in part on its contentions discussed in Sections II.E.3.f and II.E.3.g above. Pet. 72–74 (citing Ex. 1008, 11:25–31, 12:30–59, 13:1–8, 13:11–22, 13:36–62, 14:1–5, Figs. 4A, 4B; Ex. 1006 ¶¶ 778–788, 819–825).

Patent Owner does not challenge Petitioner’s contentions with respect to the further limitations of claim 10 in its Preliminary Response, and we are persuaded, on the current record, that Petitioner provides adequate evidence to support its contentions.

7. Dependent Claim 14

Claim 14 depends from claim 10 and further recites “wherein the state operations include updating the flow-entry, including storing identifying information for future packets to be identified with the flow-entry.”

Ex. 1004, 51:41–44. Petitioner contends that Riddle teaches this further limitation, relying in part on its contentions discussed in Section II.E.3.f above. Pet. 74–75 (citing Ex. 1008, 12:53–59, 13:36–62, Figs. 4A, 4B; Ex. 1006 ¶¶ 826–831).

Patent Owner does not challenge Petitioner’s contentions with respect to the further limitation of claim 14 in its Preliminary Response, and we are persuaded, on the current record, that Petitioner provides adequate evidence to support its contentions.

8. Dependent Claim 15

Claim 15 depends from claim 14 and further recites “further including receiving further packets, wherein the state processing of each received packet of a flow furthers the identifying of the application program of the

flow.” Ex. 1004, 51:45–48. Relying on disclosure in Riddle of receiving multiple packets of a flow and classifying such packets based on both a transport-layer protocol and an application-layer protocol, Petitioner contends that Riddle teaches these further limitations. Pet. 75–77 (citing Ex. 1008, 2:2–29, 10:1–18, 10:59–65, Figs. 1B, 1C; Ex. 1006 ¶¶ 832–839).

Patent Owner does not challenge Petitioner’s contentions with respect to the further limitations of claim 15 in its Preliminary Response, and we are persuaded, on the current record, that Petitioner provides adequate evidence to support its contentions.

9. Conclusion Regarding Ground 1

For the foregoing reasons, we conclude that Petitioner has demonstrated a reasonable likelihood that it will prevail in showing that the challenged claims are unpatentable over the combination of Riddle and Ferdinand, including a showing that the reasons for the proposed combination are sufficiently supported by “articulated specific reasoning with some rational underpinning, based on evidence of record, to support the legal conclusion of obviousness” at this stage of the proceeding. *See In re Magnum Oil Tools Int’l, Ltd.*, 829 F.3d 1364, 1380 (Fed. Cir. 2016) (citing *KSR*, 550 U.S. at 418).

F. Grounds 2 and 3: Obviousness over Riddle, Ferdinand, and Yu and over Riddle, Ferdinand, and RFC1945

Petitioner alleges that the challenged claims are also unpatentable as obvious over Riddle, Ferdinand, and Yu and over Riddle, Ferdinand, and RFC1945. Pet. 77–91.

Because Petitioner has shown a reasonable likelihood of prevailing with respect to the challenged claims over Riddle and Ferdinand alone, we will institute on all grounds raised in the Petition, including Grounds 2 and 3

additionally relying on Yu and RFC1945, respectively. *See SAS Inst., Inc. v. Iancu*, 138 S. Ct. 1348, 1359–60 (2018); *AC Techs. S.A. v. Amazon.com, Inc.*, 912 F.3d 1358, 1364 (Fed. Cir. 2019) (“[I]f the Board institutes an IPR, it must . . . address all grounds of unpatentability raised by the petitioner.”). In addition, based on our view of the preliminary evidence, we consider Petitioner to be reasonably likely to prevail on at least the ground based on Riddle, Ferdinand, and Yu.

1. Overview of Yu

Yu, titled “Policy Engine Architecture,” provides “an architecture 100 for applying policies to network data traffic.” Ex. 1011, code (54), 2:46–50. The architecture includes three components: an application “such as a firewall, virtual private network (VPN), or traffic management,” a “policy engine 106,” and an API 104 between these two components. *Id.* at 2:51–59.

Yu describes a “flow classification specification 203a provides the screening criteria for the flow classifier logic 204 to sort network traffic into flows,” that “[a]ll packets that match the same flow classification specification 203a form a flow,” that “a flow is a stream of correlated packets to which policy decisions apply,” and that “a flow classifier 204 classifies the packet according to one or more classification specifications 203a and finds one or more corresponding action specifications 203b.” Ex. 1011, 3:32–59. Yu further describes that a “stream is an ‘instantiation’ of a flow-packets that have the same source and destination address, source and destination port, and protocol type,” and “[p]ackets may be sorted into streams, and a flow may include one or more streams,” where “[a]ll packets belonging to the same stream are to be regulated by the same policy.” *Id.* at 4:2–9.

In Yu, “the stream classifier 207 matches the packets to a particular stream specification 208 and then, using the corresponding action specifications 210, activates the proper action processors 206.” Ex. 1011, 5:8–11.

2. *Overview of RFC1945*

RFC1945 describes version 1.0 of the Hypertext Transfer Protocol (“HTTP/1.0”). Ex. 1010, 1, 4. RFC1945 describes that HTTP/1.0 is an application level-protocol that is implemented for communications between entities such as client servers. *Id.* at 4. HTTP/1.0 provides for HTTP messages, which consist of requests from a client to a server and responses from the server to the client. *Id.* at 21. Such messages may include headers. *Id.* Further, such headers may include one or more fields. *Id.* at 37. RFC1945 describes that one of the header fields is a “Referer” request-header field, which specifies an address (“URI”) of a resource from which a URI of the underlying request message was obtained. *Id.* at 44–45.

3. *Analysis*

Petitioner’s arguments regarding these grounds are similar to those presented for the grounds based on Riddle and Ferdinand alone, discussed in Section II.E above. In these grounds, Petitioner relies on Yu or RFC1945, rather than Riddle, for the teaching of conversational flows. *See* Pet. 79–81, 85–88. With respect to Yu, Petitioner contends that “Yu’s flow classification specification provides screening criteria for flow classifier logic to sort network traffic into ‘flows’ (which include multiple streams, i.e., connection flows), such as defining a specific pair of hosts running a specific application,” where “Yu defines a ‘flow’ as ‘all packets that match the same flow classification specification’ and specifically notes that ‘a flow may include *one or more* streams.” Pet. 79–80 (quoting Ex. 1011, 3:47–49,

4:7–8) (citing Ex. 1011, 3:32–36; Ex. 1006 ¶ 430). Further, Petitioner contends, “Yu specifies ‘the matching criteria used by a flow classifier to classify a flow may include a specific value, a range, or wildcard on interface port numbers, protocols, IP addresses, TCP ports, *applications*, *application data*, or any user specifiable criteria.’” *Id.* at 80 (quoting Ex. 1011, 1:56–60). Thus, Petitioner argues, “Yu’s flow classifier links multiple ‘streams’ into a ‘flow’ based on application or application data, thus identifying the ’751 [p]atent’s ‘conversational flow.’” *Id.* With respect to RFC1945, Petitioner notes that RFC1945 describes examining HTTP header fields, including a “referrer” request header, and that contends Patent Owner’s technical expert in prior district-court litigations “testified that information from HTTP referrers are used to create conversational flows” and that “HTTP Referrer fields may satisfy the requirements of a ‘conversational flow’ by correlating connection flows.” *Id.* at 85–87 (citing Ex. 1010, 44–45; Ex. 1069, 25:18–26:7, 48:23–50:14; Ex. 1075 ¶ 3; Ex. 1076, 5). Relying on Dr. Weissman’s testimony, Petitioner further contends that a person of ordinary skill in the art “would have recognized that HTTP Referrer fields were known in the art and used to relate traffic flows,” and “Patentee’s reliance on the HTTP Referrer field as linking connection flows into a conversational flow demonstrates the obviousness of the claimed invention, at least under Patentee’s interpretation of ‘conversational flow.’” *Id.* at 88 (citing Ex. 1006 ¶¶ 445-467). Petitioner also presents reasons why a person of ordinary skill in the art would have been motivated to combine the teachings of Yu or RFC1945 with the teachings of Riddle and Ferdinand in the manner asserted and why such a person would have had a reasonable expectation of success in doing so, supported by the testimony of Dr. Weissman and disclosure in the references

themselves. *Id.* at 81–83, 89–91 (citing Ex. 1006 ¶¶ 433–440, 452–460, 854–856, 860, 861; Ex. 1008, 6:5–8, 8:41–45, 8:64–9:11, 9:24–27, 12:43–44, 13:63–64; Ex. 1010, 37–46; Ex. 1011, 1:10–13, 1:22–26, 1:63–67, 2:26–28, 2:45–50, 3:34–36, 4:1–9, 4:57–62, 5:1, 6:19–21).

Patent Owner responds that Petitioner has failed to sufficiently show that one of skill in the art would have combined Yu with Riddle and that both Yu and RFC1945 also fail to disclose “conversational flows.” Prelim. Resp. 44–48. According to Patent Owner, “Riddle focuses on a simple solution in which well-known protocols and services are automatically recognized based on port number or string matching without requiring complex configuration” while “Yu . . . touts a flexible solution in which developers can continually update the software configuration. Prelim. Resp. 45 (citing Ex. 1011, 5:47-50). Patent Owner asserts that “Riddle’s simple solution would be thwarted by the complexities introduced by Yu’s proposed system, which requires specialized hardware and regularly updated software modules.” *Id.* At this stage, we are not persuaded this would be the case. “[F]amiliar items may have obvious uses beyond their primary purposes, and a person of ordinary skill often will be able to fit the teachings of multiple patents together like pieces of a puzzle.” *KSR*, 550 U.S. at 402. Whether or not the “simple solution” of Riddle is on some level at odds with the “flexible solution” of Yu, at this stage we find persuasive Petitioner’s assertions that “like Riddle, Yu teaches using software to manage application policies to classify flows,” and that a person of ordinary skill in the art “would have looked to Yu for its teachings of flexibility and efficiency in implementing Riddle’s packet classifier.” Pet. 81–82 (citing Ex. 1006 ¶ 434; Ex. 1011, 2:45–50, 5:1, 6:19–21).

With respect to whether Yu discloses “conversational flows,” Patent Owner asserts that “[j]ust as Riddle does not differentiate between different Skype calls, Yu’s flow classification specification likewise does not differentiate between different Skype calls, which would be different conversational flows.” Prelim Resp. 47. As discussed above in Section II.E.3.c, Patent Owner does not persuade us, on this record, that the examples presented as multiple activities of the same type cannot also represent an “activity.” Therefore, Patent Owner’s argument that Skype calls would not be differentiated by Yu is unavailing.

With respect to RFC1945, at this stage we are not persuaded based on any citation to the content of the reference itself that it discloses conversational flows. Moreover, we find persuasive Patent Owner’s argument that the slides referenced at pages 86–88 of the Petition (Ex. 1074, 27, Ex. 1076, 5) go beyond “the general description of the Hypertext Transfer Protocol version 1.0, which is what RFC 1945 details.” Prelim Resp. 48.

Having considered Petitioner’s contentions in the Petition, we are persuaded that Petitioner has made a sufficient showing at this stage with respect to the teachings of Yu to establish a reasonable likelihood of prevailing with respect to the ground based on the combination of Riddle, Ferdinand, and Yu, including sufficiently “specific reasoning, based on evidence of record, to support the legal conclusion of obviousness” at this stage of the proceeding. *See Magnum Oil*, 829 F.3d at 1380; Pet. 77–83.

III. CONCLUSION

On this record, we are persuaded that Petitioner demonstrates a reasonable likelihood that it would prevail in showing the unpatentability of claims 1, 2, 5, 10, 14, 15, and 17 of the ’751 patent on at least two of the

grounds asserted in the Petition. We, accordingly, institute an *inter partes* review of the challenged claims.

Our determination in this Decision is not a final determination on either the patentability of any challenged claims or the construction of any claim term and, thus, leaves undecided any remaining fact issues necessary to determine whether sufficient evidence supports Petitioner's contentions by a preponderance of the evidence in the final written decision. *See TriVascular, Inc. v. Samuels*, 812 F.3d 1056, 1068 (Fed. Cir. 2016) (noting that "there is a significant difference between a petitioner's burden to establish a 'reasonable likelihood of success' at institution, and actually proving invalidity by a preponderance of the evidence at trial") (quoting 35 U.S.C. § 314(a) and comparing *id.* § 316(e)).

IV. ORDER

In consideration of the foregoing, it is hereby:

ORDERED that pursuant to 35 U.S.C. § 314(a), an *inter partes* review of claims 1, 2, 5, 10, 14, 15, and 17 of the '751 patent is instituted, commencing on the entry date of this decision; and

FURTHER ORDERED that pursuant to 35 U.S.C. § 314(c) and 37 C.F.R. § 42.4, notice is hereby given of the institution of review.

IPR2020-00338
Patent 6,839,751 B1

PETITIONER:

Joseph F. Edell
Adam A. Allgood
FISCH SIGLER LLP
joe.edell.ipr@fischllp.com
adam.allgood@fischllp.com

Scott A. McKeown
Mark D. Rowland
ROPES & GRAY LLP
scott.mckeown@ropesgray.com
mark.rowland@ropesgray.com

PATENT OWNER:

R. Allan Bullwinkel
Michael F. Heim
HEIM PAYNE & CHORUSH, LLP
abullwinkel@hpcllp.com
mheim@hpcllp.com